

PITELUMEC

THE PRING-E 365 RING BIT CASING SYSTEM

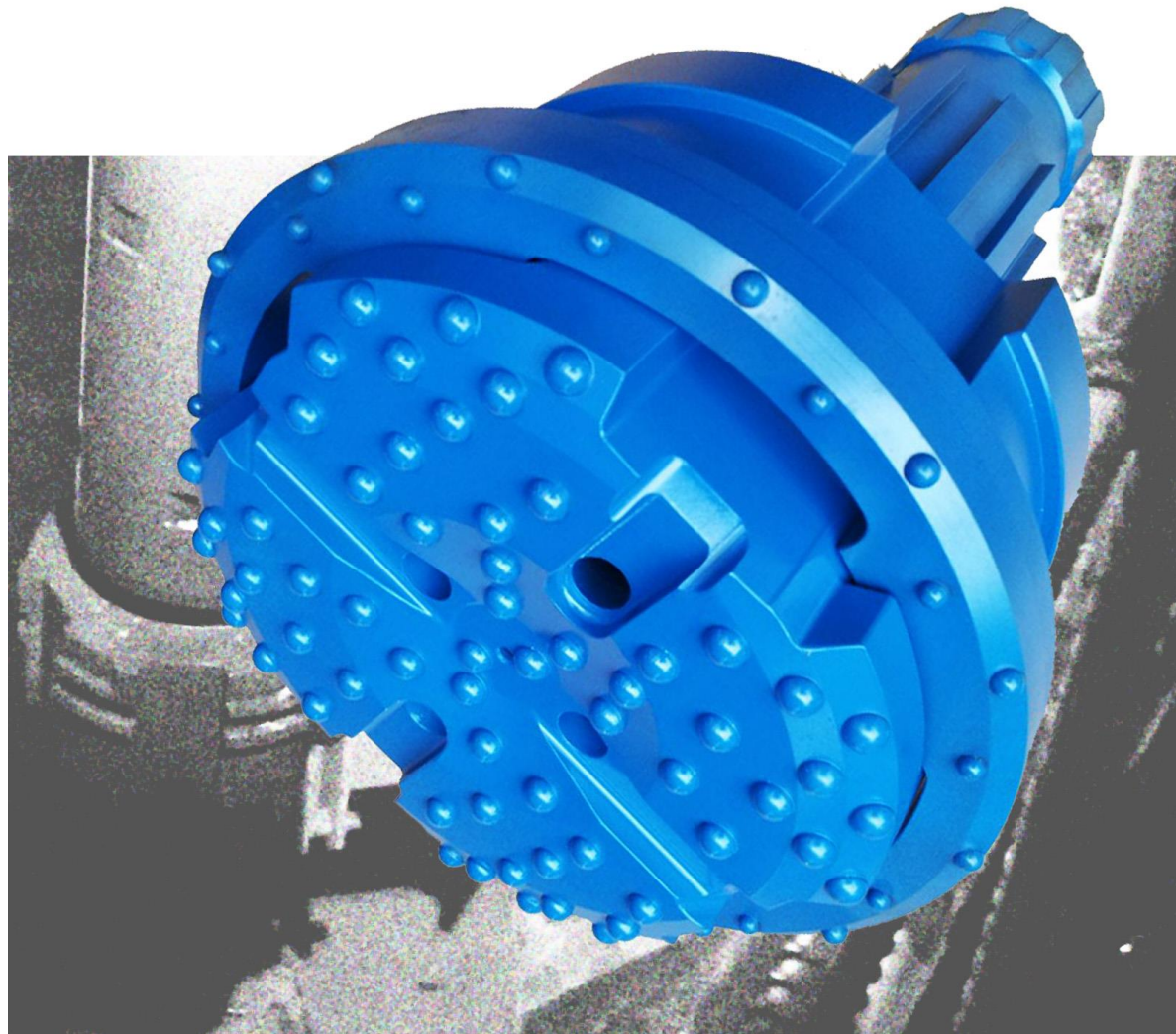

CASING SIZE 406MM OD X 387MM ID DRILLING DIA. 430MM

PNEUMEC PRING-E 365 CASING SYSTEM

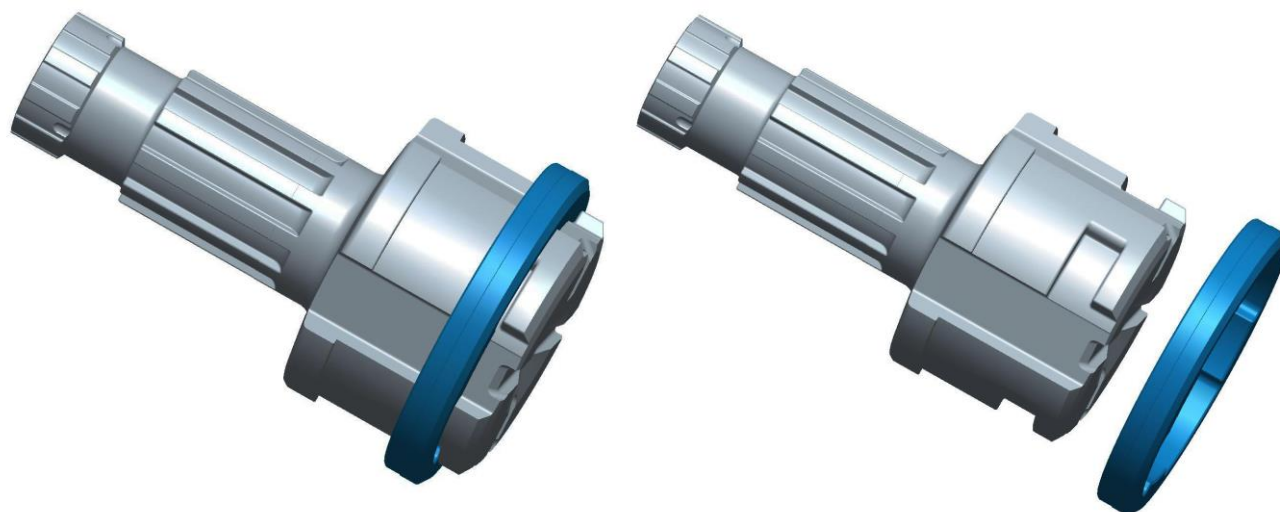

PRING-E 365 PARTS LIST

1.	DRIVER BIT N125 SHANK	UGD365125RE
2.	RING	URB365RE
3.	COMPLETE SYSTEM	UCS365125RE

PRING-E 365 SPECIFICATIONS

UPPER BODY DIAMETER	380MM	RING ID	320MM
RING OD	430MM	CASING SIZE	406MM OD X 387MM ID
SYSTEM LENGTH	780MM	SYSTEM WEIGHT	330KG

PRING-E 365 CASING SHOES

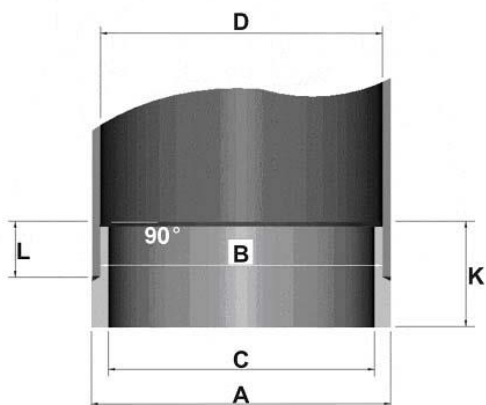

DIA. A	406MM
DIA. B	384MM
DIA. C	358MM
DIA. D	387MM
L	40MM
K	90MM



PNEUMEC COMPANY LIMITED

1st Floor, Tin On Sing Comm. Bldg., 41-43 Graham St. Central, H.K.

Tel : (852) 2180 9922

Website : www.pneumec.com

Fax : (852) 2180 9982

email : info@pneumec.com